

RBW50H PASS THROUGH BOTTLE WASHER

The RBW50H is perfect for small to medium sized operations washing bottles with an opening of 10mm upwards. The cycle time ranges from 120 to 180 seconds. The design of this range uses specially made manifolds to ensure the inside of the bottle is thoroughly cleaned.

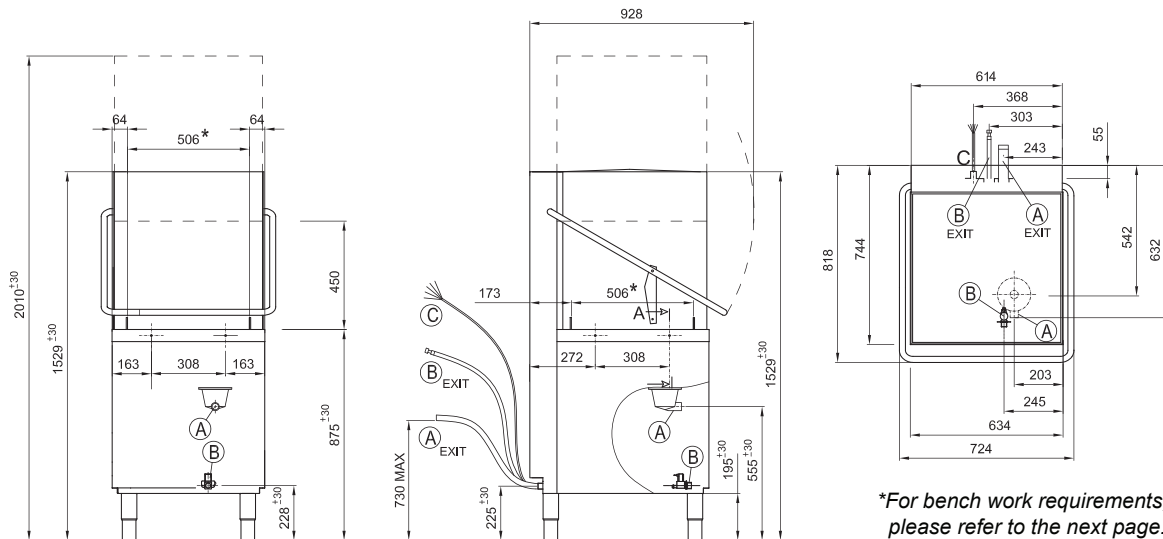

Standard Features

- 3 cycles (wash only, rinse only, wash & rinse)
- Built-in detergent & rinse aid dispenser
- Standard rack fits 25 bottles of any shape up to 95mm diameter
- Thermostop system ensures 100% sanitisation
- Drain pump to allow for easy connection to drain
- Heavy duty, commercial grade construction
- Designed & manufactured in Australia



**WATER
SAVING**



**ECO
FRIENDLY**



Power supply	415V
Total power	7.1KW
Total current	16 Amp
Wash tank capacity	15 ltrs
Water consumption (wash & rinse cycle)	15 ltrs
Rinsing temp (approx)	75°C
Rack size	500mm x 500mm
Tallest washable item	42 cm
Weight (empty)	92 kg
Water connection (Hot*)	3/4" hose

*Connect to hot water for optimum performance

BENCH WORK DETAILS

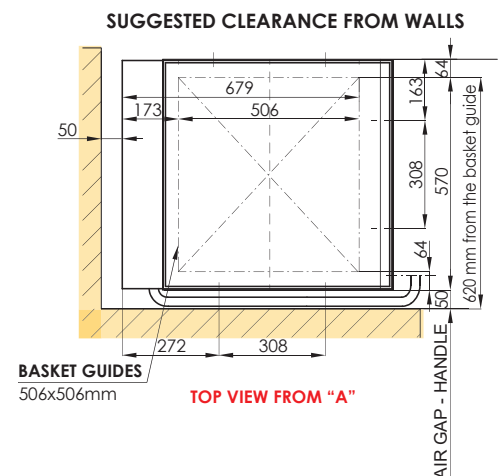
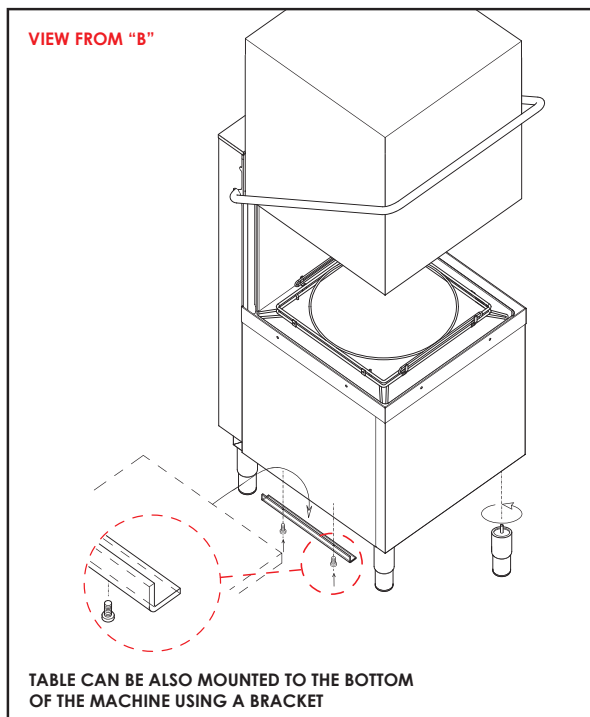
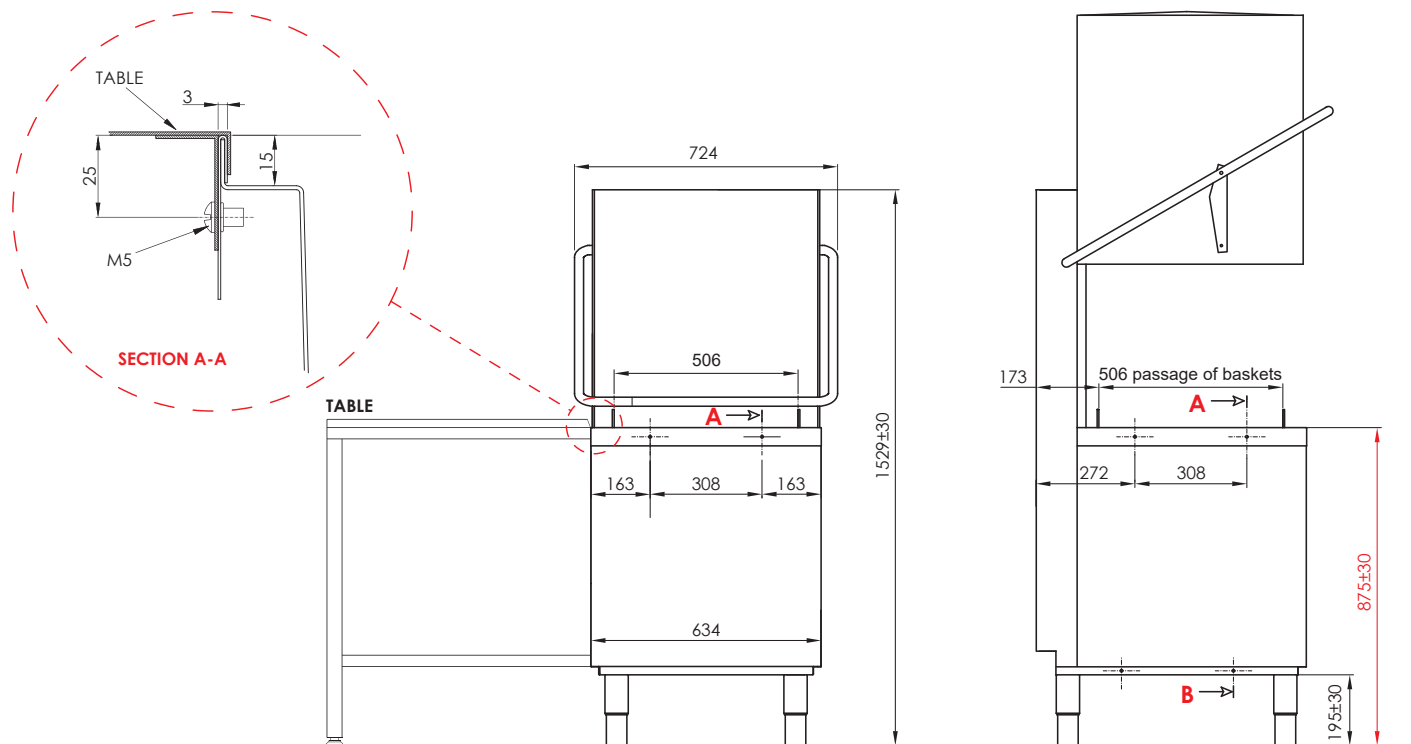

Note: Dimensions shown are a guide only. Benching design/measurements may vary depending on individual site requirements. Rhima suggests final benching design is done with washer in place.